

APEX® RF GENERATORS AND POWER-DELIVERY SYSTEMS

Sophisticated RF Conversion Technology

APEX® RF GENERATORS AND POWER-DELIVERY SYSTEMS

The versatile Apex® family of RF generators provides remarkably high power density and power-delivery consistency. Sophisticated RF conversion technology not only offers enhanced product and process reliability but also increases cost effectiveness by eliminating the need for front-end, DC-to-DC conversion components.

Exceptionally fast and sensitive arc-handling technology also increases yield and lowers CoO. For superb performance in plasma-based, thin-film processes for semiconductor, flat panel display, or data storage manufacturing, the Apex platform is the ideal choice. With its unique, modular design—in a package so trim it can be mounted directly on the chamber—the Apex platform is also highly customizable to suit your specific process needs.

Benefits

- Higher power density
- Improved process flexibility
- Increased yield
- Lower CoO
- Simplified process tool integration
- Flexible communications

Features

- Streamlined design
- On-board chamber mount, on-tool frame mount, rack mount, and shoebox options
- Wideband control loops and optional, high-repetition-rate pulsing
- Industry-leading arc management
- Regulatory compliant

Innovative RF Technology

Leveraging truly innovative RF conversion technology, the Advanced Energy® (AE) Apex family of RF generators provides higher power density, greater delivered power repeatability, increased reliability, and superior return on investment (ROI) compared to conventional RF generators.

The Apex platform includes rack-mountable 1.5 to 10 kW models. A comprehensive set of configurable features allows you to customize the Apex platform to suit your specific process needs. The result is a completely customized unit—without lengthy custom-generator lead times.

Comprehensive, Configurable Feature Set

Advanced RF Measurement	HALO (High Accuracy Low Output)	CEX
Input Voltage (Nominal VAC)	Pulsing	Custom Analog I/O
Packaging	Custom Serial I/O	Custom Power Output (Watts)
Selectable Output Connector Type	Selectable AC Power Input Connector Type	Industry-Leading Arc Management
Water-Fitting Threads	VFP	

Typical Market Applications

The Apex platform's field-proven, superb performance in plasma-based, thin-film processes makes it ideal in manufacturing processes for:

- Semiconductors
- Flat panel displays
- Data storage devices
- Solar cells

Higher Power Density

The innovative Apex platform's unique technology eliminates typical front-end conversion components—increasing power density to give you more power, dollar for dollar.

Improved Process Flexibility

All Apex models use control loops to ensure stable plasma operation over a broad process regime. In addition, optional, high-repetition-rate pulsing enhances your ability to develop advanced processes.

Increased Yield; Lower CoO

As process geometries shrink, RF arcing is a growing source of yield loss and tool damage. The exceptional speed and sensitivity of AE's arc management technology both minimizes potential damage and preserves plasma ignition to maximize productivity. This technology rapidly detects and extinguishes micro-arcs that conventional approaches often miss. The damage caused by these neglected arcs may go undiscovered until late in the manufacturing process, which increases the dollars wasted on bad devices. Apex generators also eliminate hard RF arc damage to process equipment, lowering CoO by improving tool uptime and throughput.

Simplified Process Tool Integration

Apex models are 50 to 75% smaller than previous AE systems and more than 75% smaller than competing systems. The Apex platform maximizes placement options and simplifies installation. Mounting configurations include on-board chamber mounts, on-tool frame mounts, and rack mounts. The on-board chamber configuration eliminates 10 to 25% of the power losses typical of conventional RF systems. The non-rack-mount Apex configuration is shoebox-sized, enabling minimal-footprint OEM solutions.

Flexible Communications

The versatile Apex platform offers multiple communications models, making it easy to integrate with your process tools. All models include RS-232 communication and enable easy addition of other digital serial interface options, including Profibus and DeviceNet® protocols.

Regulatory Compliant

All Apex models are CE marked and comply with other European industrial safety standards, including EN50178, and EMC standards EN50091-2 and EN50082-2. In addition, they meet FCC Part 18 requirements for ISM equipment as well as SEMI S2 and F47 guidelines. Most models also comply with North American Industrial Safety Standards UL1012 and CSA 107.1.

Specifications

Physical	1.5 kW	3 kW	5.5 kW	10 kW
Dimensions (Including Rear Connections)	132.59 mm (H) x 215.14 mm (W) x 425.96 mm (D) 5.22" (H) x 8.47" (W) x 16.77" (D)			133.35 mm (H) x 482.6 mm (W) x 601.29 mm (D); 5.25" (H) x 19 (W) x 23.67" (D) 3U 19" rack

Electrical	1.5 kW	3 kW	5.5 kW	10 kW
Frequency	13.56 MHz			
RF Output Power and Regulation				
Forward Delivered (Fwd/Del) Power Into a 50 Ω Non-Reactive Load	1.5 kW	3 kW	5.5 kW	10 kW
Fwd/Del Power (2:1 VSWR)	1000 W	2000 W	3630 W	6600 W
Fwd/Del Power (3:1 VSWR)	750 W	1500 W	2500 W	4000 W
Harmonics	All full-rated output, -40 dBc forward/load when operated into a 50 Ω non-reactive load			
Output Accuracy				
Forward Power Regulation	±1% of set point or ±0.1% full-rated output power, whichever is greater, when measured into a 50 Ω non-reactive impedance			
Load Power Regulation	±3% of the load power into a 3:1 VSWR non-reactive load			

Environmental	1.5 kW	3 kW	5.5 kW	10 kW
Ambient Operating Temperature	5°C (41°F) min, 40°C (104°F) max			
Water Coolant Temperature	35°C (95°F) max			

Dimensional Drawing—1.5 kW, 3 kW, and 5.5 kW Models

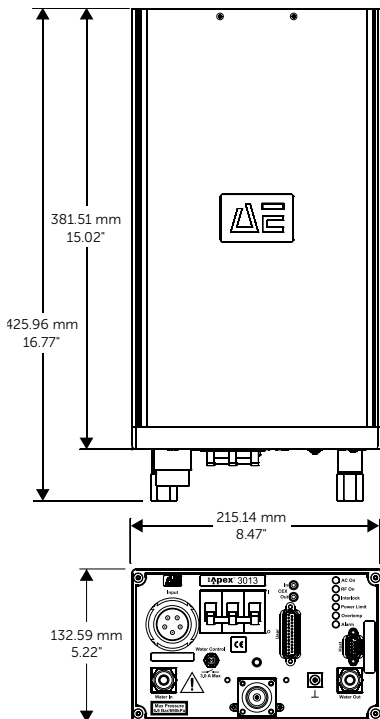

Dimensional Drawing—10 kW Model

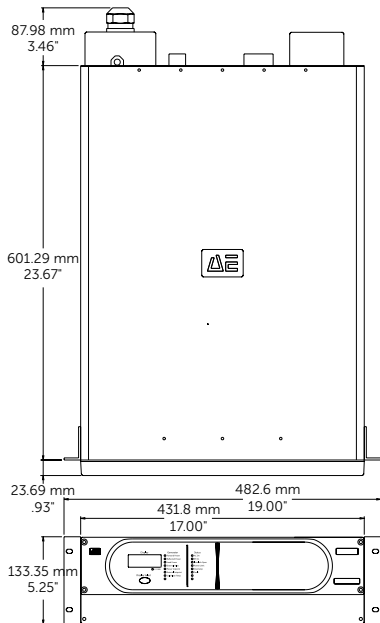

Advanced Energy Industries, Inc.
1625 Sharp Point Drive
Fort Collins, Colorado 80525 U.S.A.

T: 800.446.9167
F: +1.970.221.4670

www.advanced-energy.com

Specifications are subject to change without notice.

Advanced Energy® and Apex® are trademarks of Advanced Energy Industries, Inc. · DeviceNet® is a trademark of the Open DeviceNet Vendor Association, Inc. (ODVA).

ENG-Apex-210-06 0M 10.12