

Advanced Ignition of Remote Plasma Sources Using Pulsed Ignition and Power Load Distribution with Multiple Igniters

Created by

Advanced Energy Industries, Inc.

Abstract

Semiconductor manufacturers face ever-increasing pressure to maximize yield. Ignition failures of remote plasma sources undermine that goal, causing tool shutdown and process disruption.

This paper describes the advantages of Advanced Energy's Xstream®, which utilizes pulsed power for ignition and a transformer induced power delivery system during chamber cleaning operations. Advanced Energy has designed Xstream's pulsed power with multiple igniters (as opposed to a single-igniter design) to optimize error-free ignition, even during cold starts. We also employ a dual-transformer induced power delivery system to the main power system that enables stable transition from ignition mode to operation mode. Finally, Xstream's multiple segments of electrodes extend chamber life by distributing voltage load across the plasma chamber.

As a result, Xstream can help semiconductor manufacturers improve yield by decreasing unwanted sputtering and eliminating ignition failure during the production process. Advanced Energy has demonstrated these advantages through testing and provides the details of this test below.



Table of Contents

Xstream Plasma System	2
Conclusions	10
References	10

Xstream Plasma System

1. Plasma in Xstream

1.1 Gas breakdown and plasma sustaining

Plasmas can be classified into two main categories:

1. Fully ionized plasmas where the ions and electrons are close to thermal equilibrium, which are referred to as “hot plasmas” and
2. Weakly ionized plasmas operating in non-equilibrium, which are referred to as “cold plasmas”

Weakly charged plasma is primarily used in the semiconductor manufacturing process. One of the characteristics of cold plasma is its quasi-neutrality, which means that the bulk of the plasma contains a roughly equal amount of positive and negative charges. In other words, the average flux of positive charges and negative charges leaving the plasma are identical. On the other hand, electrons are much more easily energized and more mobile than ions, and therefore escape the plasma faster than the ions. To equalize the flux of ions and electrons, the plasma is charged to a positive potential compared to its boundaries. As a result, a space charge region, called the sheath, builds up between the plasma and all the surfaces. Positive charges are accelerated in the sheath outwards from the plasma while the negative charges (especially the electrons) are repelled into the plasma.

After ignition, external electron excitation is required to sustain plasma. This excitation is generally performed using an external radio frequency (RF) electromagnetic field that excites and accelerates the electrons. The frequency is generally too high for the low-mobility ions to follow the electromagnetic field variations, while the light and mobile electrons follow the variations of the electromagnetic field. Therefore, most of the energy is delivered to the electrons.

There are several modes of RF excitation: capacitive coupling, inductive coupling/ transformer coupling, and microwave coupling. Xstream uses transformer coupling (TCP) and, to ensure proper injection of power, an active matching network to align the output impedance of the power supply with the impedance of the plasma.

1.2 Downstream Plasmas

Remote plasma sourcing is the process methodology in which the plasma chamber is separate from the wafer process chambers. Among the various RF couplings, TCP has been widely used for many years for remote plasma generation. One of the main advantages of TCP is that the

power capacitively coupled into the plasma is minimized, resulting in a decrease in chamber wall damage through ion bombardment and, consequently, extending lifetimes for the plasma chambers. As you see in Figure 1, magnetic cores excited by an RF current coil confine fields around in the cross-section of the Xstream chamber.

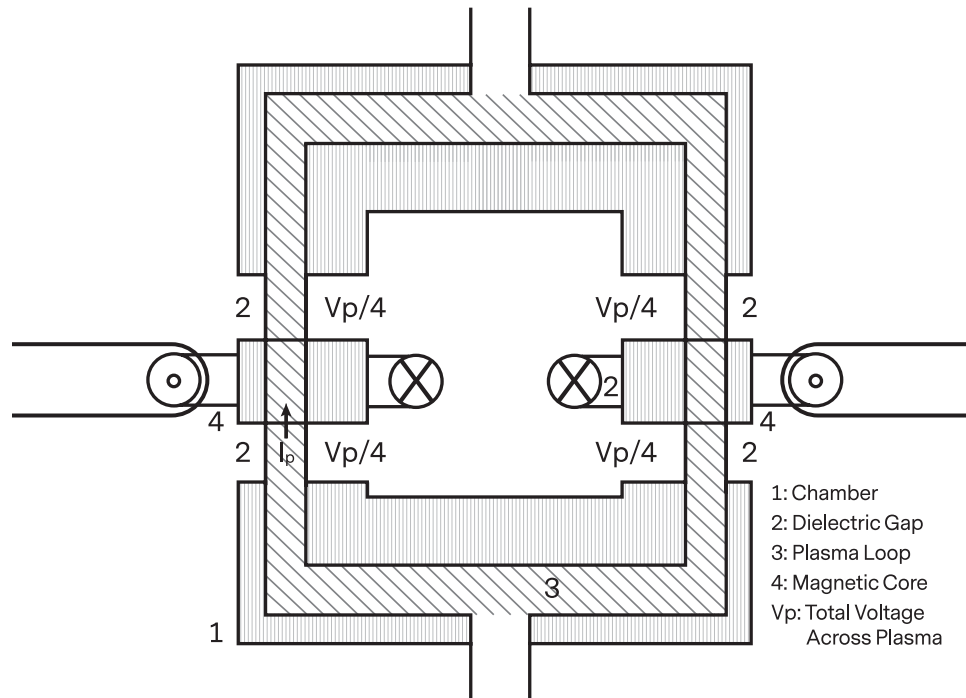

Figure 1. RF current and induced field

The transformer-coupled electric field accelerates electrons and causes ionization collisions. This allows electrons to travel in a circular motion and reduces the chance of electrons colliding with chamber walls or electrodes.

Meanwhile, neutral species can diffuse from the plasma source to the chambers, but ions are repelled or neutralized before they reach the process chamber downstream. As a result, only the radicals, which are electrically neutral and chemically reactive, are delivered to the wafer chamber.

2. Xstream Plasma System Configuration

2.1 Xstream Chamber: Dielectric breaks and multiple electrode arrangement

In Xstream, the magnetic core of the excitation transformer is placed around the vacuum chamber where the primary winding of the transformer is excited with RF; the electromagnetic field induced around the core sustains gas discharge within the vacuum chamber (Figure 1). The vacuum chamber is a metal vessel that includes four dielectric gaps to eliminate the possibility of

ADVANCED IGNITION OF REMOTE PLASMA SOURCES

creating a closed current loop through the chamber. The excitation transformers distribute total induced voltage among the four dielectric breaks to prevent wall damage that can be caused by arcs or sputtering.

To ensure operator safety, the chamber body is grounded at the top, where the gas line feed meets the chamber, and at the bottom, where the pump line exits the chamber. Grounding both sections and having both transformers close to one of the dielectric gaps results in short circuits across the gap and full voltage drop (V_p) across the gap closer to the transformer cores.

The voltage appearing across the dielectric gap can cause arcs to occur between the plasma and the chamber walls, causing deterioration of the wall surface. In addition, during plasma operation, ions from the plasma are accelerated by this potential drop, bombarding the chamber wall, and increasing the deterioration of the wall through sputtering and enhanced chemical reactions between the energetic ions and the wall material. The deterioration increases as the voltage at the gap increases. Consequently, it is important to reduce the voltage in the gap while keeping the driving voltage in the plasma unchanged.

By Faraday's law of induction, we know that the flux of magnetic cores is proportional to voltage drop along the perimeter of the chamber wall and across the dielectric breaks, and is equal to the plasma voltage, V_p . Therefore, by using four dielectric gaps, the voltage drop is distributed equally per gap and the load is $V_p/4$ for each gap (see Figure 1).

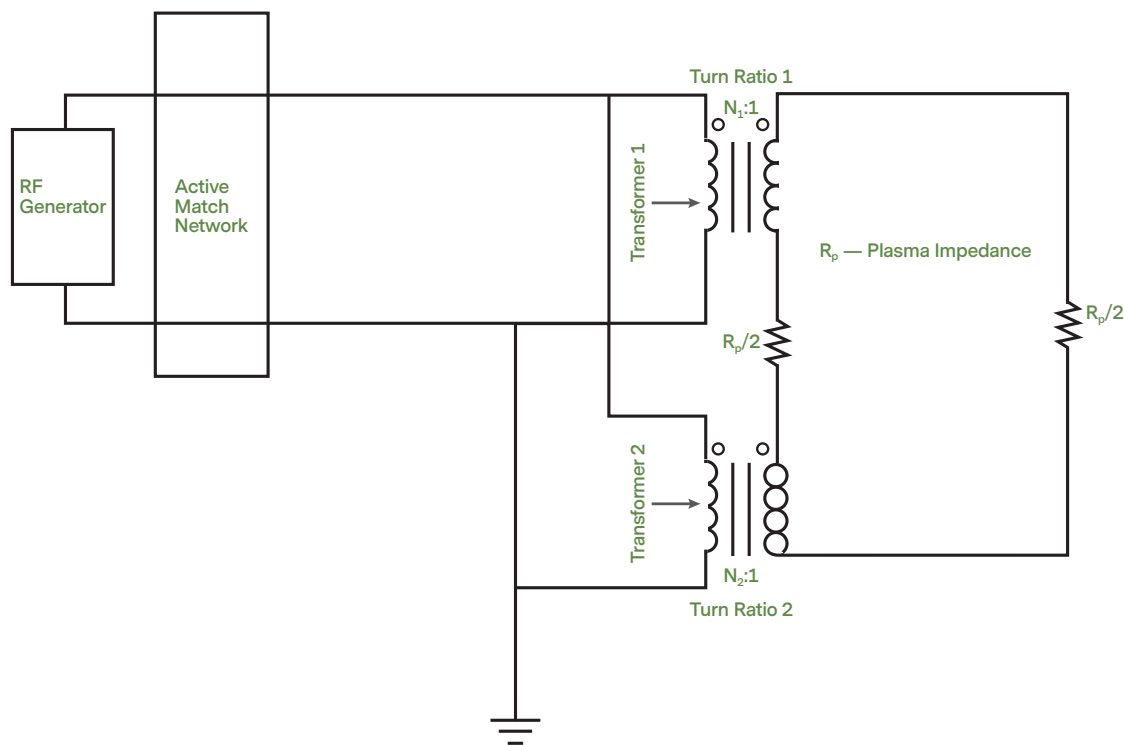

Figure 2. Schematic diagram of Xstream main power supply

In Figure 2, you see that the RF generator is coupled to the primary winding of transformers 1 & 2. The secondary windings of the transformers and the resistance represent the plasma load ($N_1:1$ and $N_2:2$) Two resistors in series now represent the total resistance of the plasma; each is one-half of the full loop plasma resistance. The implementation of multiple transformers at multiple dielectric breaks distributes the plasma voltage among the dielectric breaks, thus minimizing the voltage drop at any dielectric break.

2.2 Electric Power Supply: Transformer Power Delivery to Ignition Power Board

There are advantages with using TCPs. However, TCPs also pose a problem for plasma ignition, since the capacitive fields are needed to start the discharge. Xstream addresses this problem by introducing an auxiliary capacitive discharge, so that free charges within the plasma chamber are established in the inductively coupled plasma. This capacitive discharge is driven by an external voltage circuit, called ignition circuit (Figure 3).

ADVANCED IGNITION OF REMOTE PLASMA SOURCES

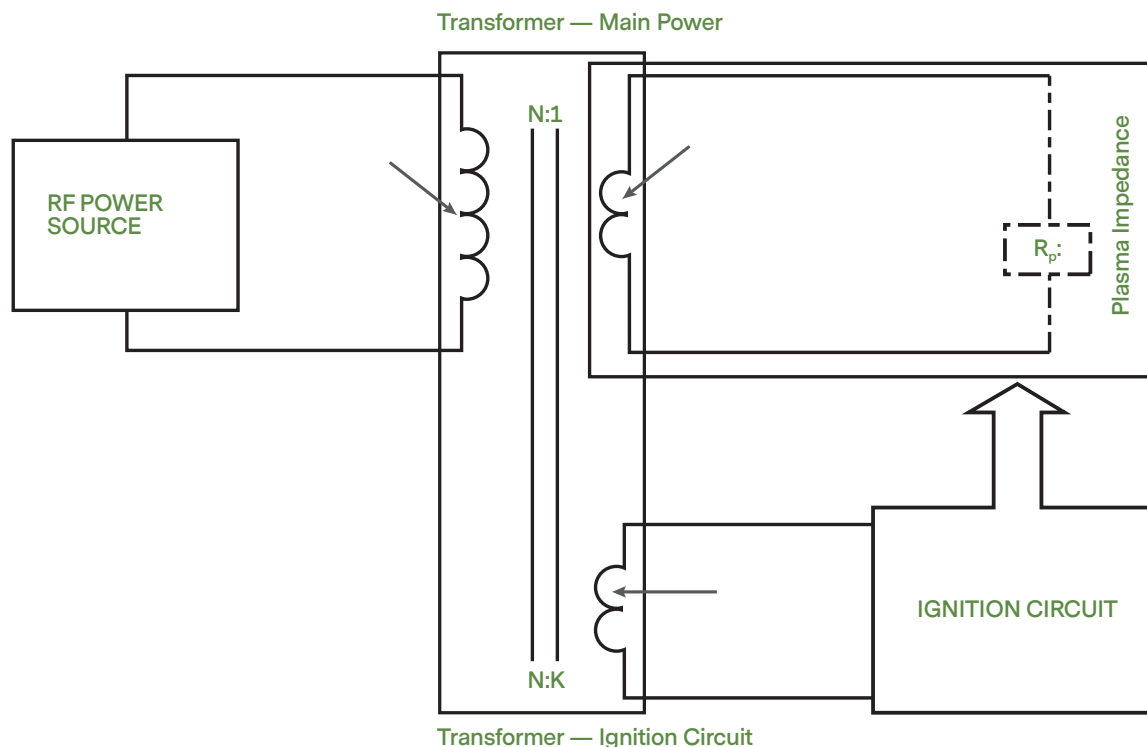

Figure 3. Schematic diagram of Xstream Ignition power supply

The plasma chamber is ignited by an ignition circuit (described in Figure 4) that couples power to the plasma source via capacitive discharge. This discharge generates free charges that are used to establish the inductive plasma discharge. Xstream uses two ignition electrodes, called Core 1 and Core 2, to ignite the plasma.

3. Voltage Load Change Test

We tested Xstream to verify the change of loaded voltage before and after ignition. The test was done at power, 5 kW, on the RF power source (Figure 4); capacitor values were $C = 1100$ pF (3 WIMA capacitors 3300 pF in series) each. An igniter was connected to the top of the front ignition core and bottom of the ignition core. Note that the ignition core adds $\frac{1}{2}$ turn, and this voltage should ADD to the 3-turn voltage of the ignition winding. Also note that there is a simple way to check polarity: voltage on the bottom gap of the front ignition Core 1 should be larger than voltage on ignition Core 2 at the top gap. During the test, the voltage on Core 1 was $V = 685$ V (at match position $M = 1$). Max voltage on the ignition gap was 720 V with a mixture of Ar 50% and O₂ 50% plasma gas. The voltage on the other gap was calculated to be $685 - 720/6 = 565$ V. The frequency when ignited was 290 kHz, and it switched to 400 kHz when plasma was ON. The total voltage load on ignition core was measured about 1.4k Vpp, as expected. The test was conducted in the same manner with powers at 8 kW and 10 kW; results are shown in Table 1.

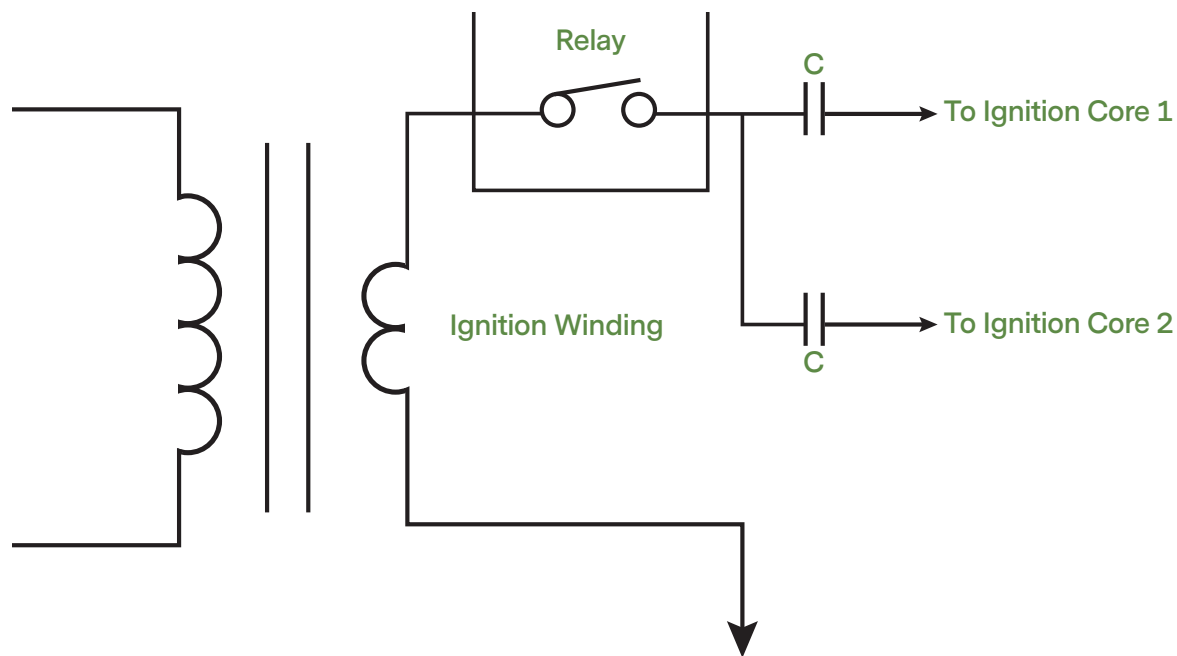

Figure 4. Schematic diagram of the ignition circuit

Load Power (kW)	Pre-Ignition		Post-Ignition	
	Voltage (Volt)	Frequency (kHz)	Voltage (Volt)	Frequency (kHz)
5	720	290	95	450
8	720	290	150	442
10	720	290	300	360

Table 1. Load voltage and frequency change between pre- and post-ignition

ADVANCED IGNITION OF REMOTE PLASMA SOURCES

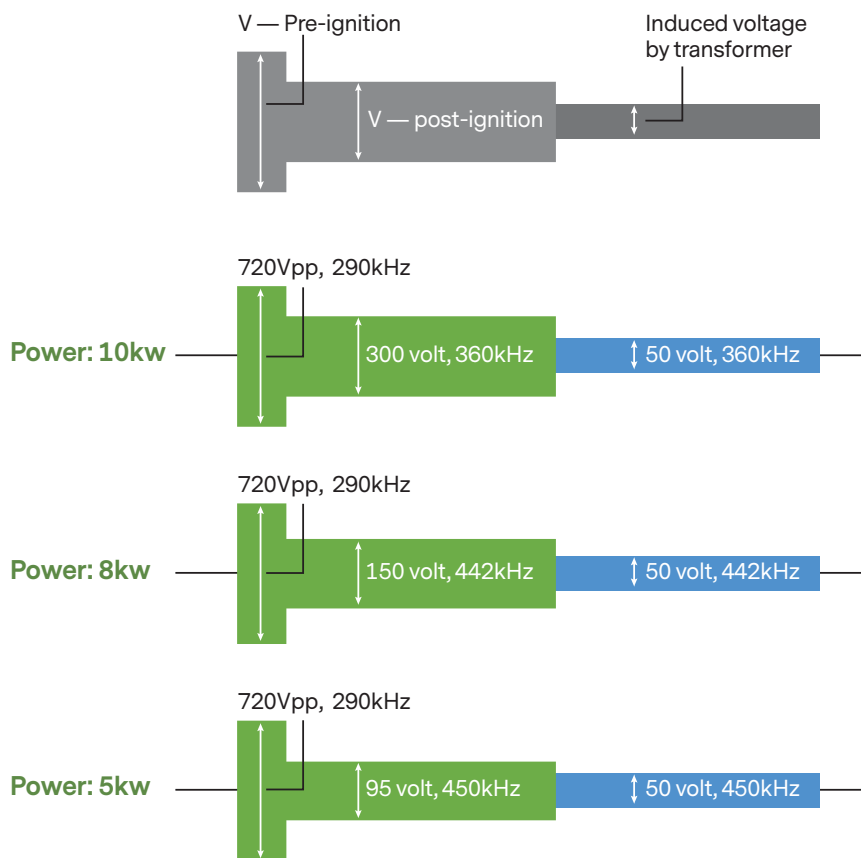

Figure 5. Load power properties of Xstream igniter

4. Pulsed Ignition Power Delivery

While Xstream is in idle mode, typical pressure in chamber is approximately a few Torr. In the vacuum, air molecules, water, fluoride gases, and precursors diffused from the process chambers can adsorb on the surface and deteriorate electrodes. As a result, the gas breakdown voltages shift up due to the contaminants (see Figure 6). To avoid the ignition failure due to breakdown voltage shift, RF modulated pulses are used to overcome the effects of the contaminants. The alternative voltage of the pulses applied on the electrodes can repel the electronegative gases adsorbed on surfaces and helps sustain plasma.

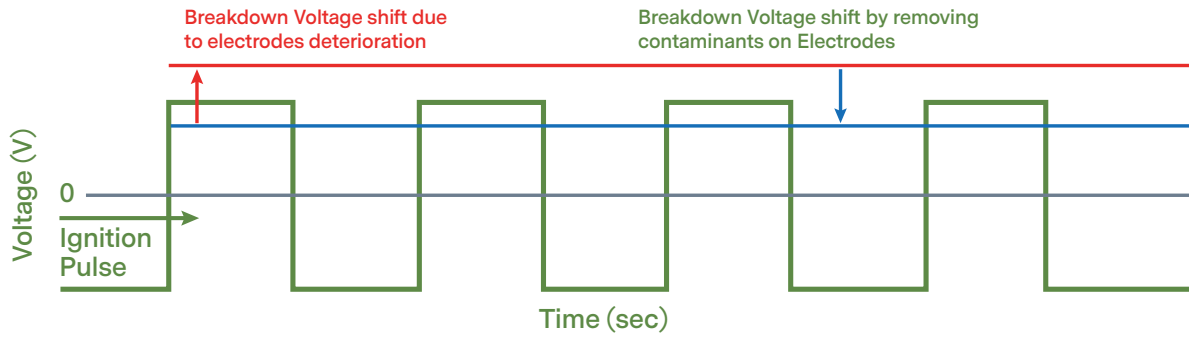

Figure 6. Breakdown voltage shift due to electrode deterioration.

Power	Gas Flow	Pressure*	Time **
4 kW	Argon, 2.3 lpm	0.76 Torr	10 secs

*Pressure measured at gas outlet

**10 breaks per each test to facilitate cold start conditions

Table 2. Frequent ignition failure in a CVD manufacturing process

Figure 7 shows the sequence of pulsed ignition. After a start, ignition ON and OFF steps are repeated until the end time defined by program. In the test, ignition power was programmed to be loaded for 1.5 sec per cycle and repeated for 20 cycles. The test repeated a total 12,000 times with 10-minute breaks. In most cycles, ignition occurred after two ignition pulses. No ignition fail was observed during the repeated cycles.

The typical voltage behavior during ignition is shown in Figure 8. After ignition, voltage and current drop simultaneously to the induction level driven by main power board.

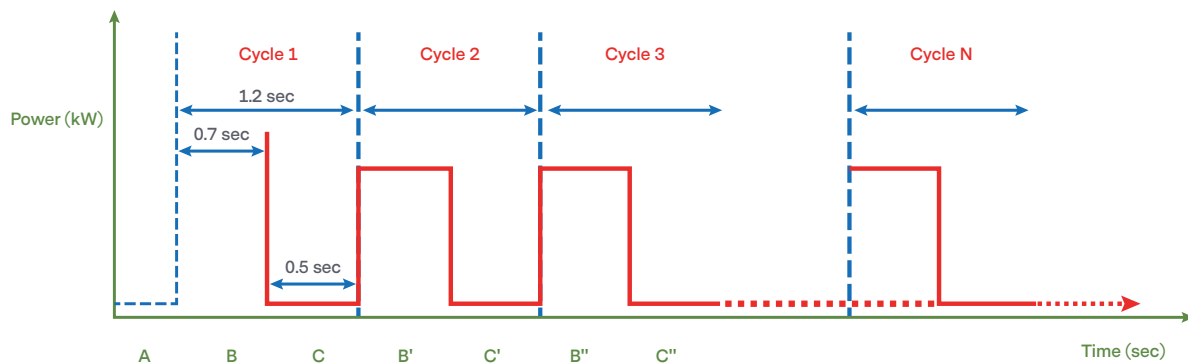

Figure 7. The sequence of pulsed ignition

ADVANCED IGNITION OF REMOTE PLASMA SOURCES

Symbol	Command	Time
A	Ready	1.5 sec
B/B'/B''	Ignition Board ON	0.7 sec
C/C'/C''	Ignition Board OFF	0.5 sec

Table 3. Pulsed-ignition program parameters

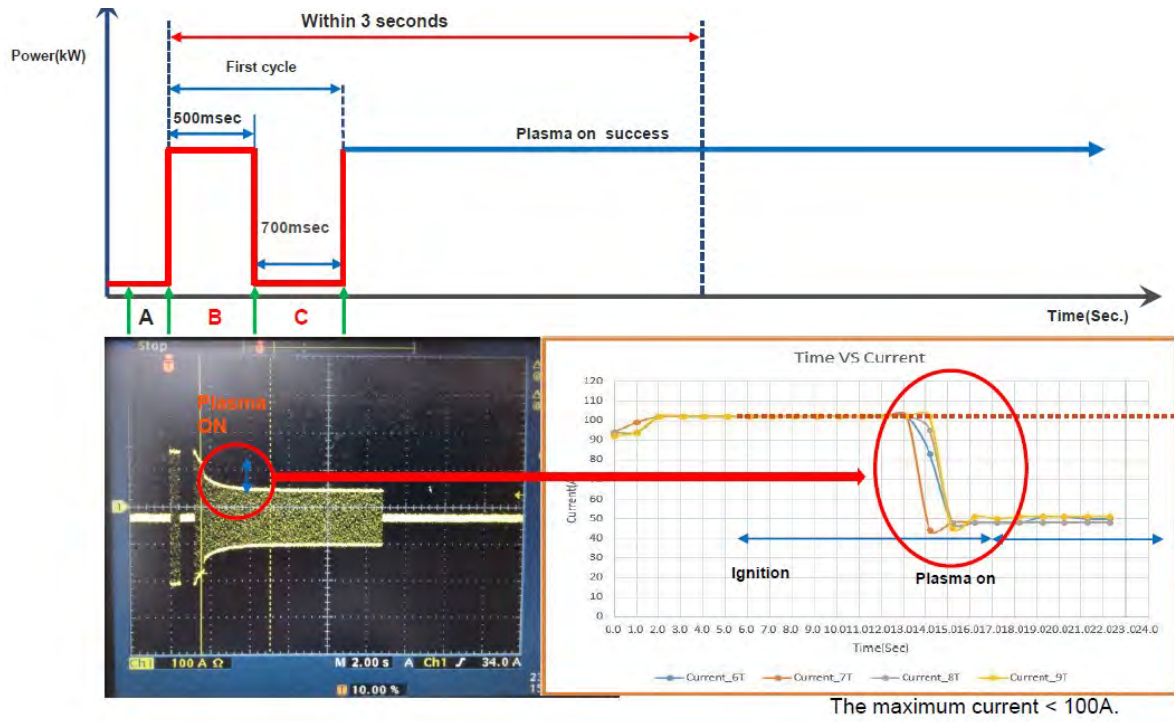

Figure 8. Ignition pattern typically seen in pulse-power ignition

Conclusion

In this study, the power load distribution and ignition processes have been tested to verify the proper transition from ignition to operation mode using Xstream RPS. Most significantly, the new ignition method has been tested and validated for successful ignition, even in a cold start environment. In an in-house, marathon test (12,000 ignitions), the 4-point ignition electrodes performed exceptionally well. Also, no ignition error occurred in a field test in which Xstream was used to ignite plasma 20,000 times.

The results are very promising in terms of MTBF (mean time between failure). The data from 30 test units implementing Advanced Energy's Xstream in semiconductor fabrication shows that no ignition failure has been observed over 26 months.

Advanced Energy has designed Xstream specifically to address semiconductor fabrication challenges that decrease yield. The combination of Xstream's load power distribution design and pulsed ignition system provides reliable and stable performance and improves yield by decreasing the operational failure rate during the manufacturing process.

References/Sources

Chen F.F., Chang J.P. Lecture Notes on Principles of Plasma Processing. Springer Science & Business Media; 2012.

Lieberman M., Lichtenberg A.J. Principles of Plasma Discharges and Materials Processing. 2nd ed. Wiley; 2005.

Appl. Phys. Lett. 42, 416 (1983);

United States Patent, US 6,724,148 B1

United States Patent, US 7,005,845 B1

United States Patent, US 6,822,396 B2



For international contact information,
visit advanced-energy.com.

sales.support@aei.com
+1.970.221.0108

ABOUT ADVANCED ENERGY

Advanced Energy (AE) has devoted more than three decades to perfecting power for its global customers. AE designs and manufactures highly engineered, precision power conversion, measurement and control solutions for mission-critical applications and processes.

AE's power solutions enable customer innovation in complex semiconductor and industrial thin film plasma manufacturing processes, demanding high and low voltage applications, and temperature-critical thermal processes.

With deep applications know-how and responsive service and support across the globe, AE builds collaborative partnerships to meet rapid technological developments, propel growth for its customers and power the future of technology.

PRECISION | POWER | PERFORMANCE

Specifications are subject to change without notice. ©2018 Advanced Energy Industries, Inc. All rights reserved. Advanced Energy®, AE®, and Xstream® are U.S. trademarks of Advanced Energy Industries, Inc.